



---

# **ADJUSTABLE TURNBUCKLES**

**INSTRUCTION MANUAL**

---





## CONTENTS

<b>TURNBUCKLES</b>	<b>PG. 3</b>
M8 STANDARD	PG. 3
M8 SHORT	PG. 3
M10 STANDARD	PG. 4
M6 STANDARD	PG. 4
SINGLE END TURNBUCKLE	PG. 5
<b>FITTING INSTRUCTIONS</b>	<b>PG. 6</b>
DOUBLE ENDED TURNBUCKLE	PG. 6
SINGLE ENDED TURNBUCKLE	PG. 7

To successfully fit your Shade sail you may need additional attachments, to bridge the gap between your fixing and chosen anchorage point. A correctly tensioned Shade Sail is the key to its longevity, so when choosing hardware it is important take the specifics of each product into consideration.

There are some key rules of thumb to keep in mind when fixing your Shade Sail using turnbuckles:

1. Work around your Shade sail slowly tensioning each corner ensuring that the tension is even across the sail.
2. Stop tensioning once the sail is rigid and flat with no creases.
3. Make sure that you tightly secure the fixing once happy with the tension to reduce slipping.  
*For example with turn buckles make sure the nut is tightened.*
4. Make sure that you have allowed for future tensioning of the Shade Sail  
*For example, make sure there is thread left on the screw, or distance between the corner of your shade and the anchor point.*

Below are a series of products that can improve the fit of your Shade Sail these are all available to be purchased online:



### LONG D SHACKLE

KSFX7060 // approx. 50mm ALLOWANCE

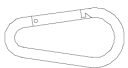

### CARBINE HOOK

KSFX9060 // 6mm x 60mm External Dimensions



### LONG LINK CHAIN

KSFX35LL // 5mm Diameter, sold by the metre



### WIRE STROP

KSFXE010 // KSFE020 // KSFXE030, manufactured to specification  
0 - 1M // 1 - 2M // 2 - 3M



## TURNBUCKLES

Each end are threaded in opposite directions so that when you rotate the body of the turnbuckle one way tension will be increased, rotate the other way and tension will be released. A versatile fixing which allows for adjustments in precise increments, there is a large variety of turnbuckles that have fork - fork attachments.

### M8 STANDARD

KSFx81CB

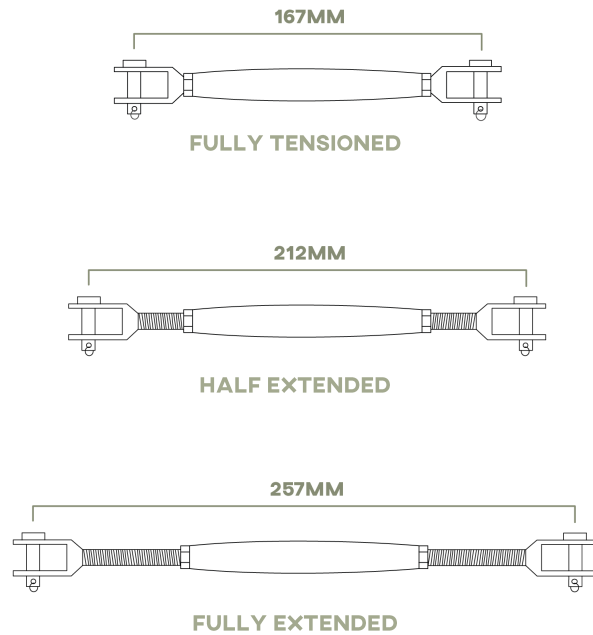
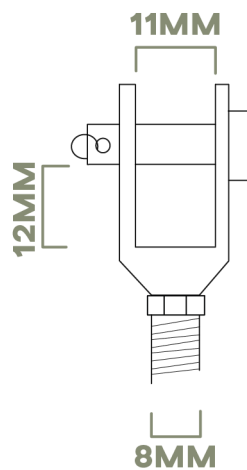

### M8 SHORT

KSFx81SH

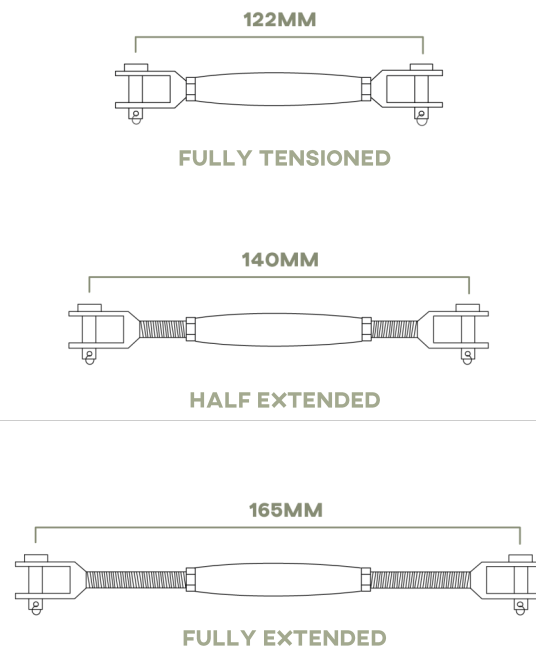
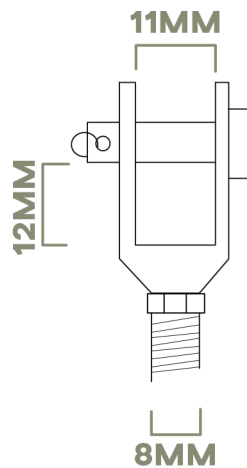



## TURNBUCKLES

### M10 STANDARD

KSFX01CB

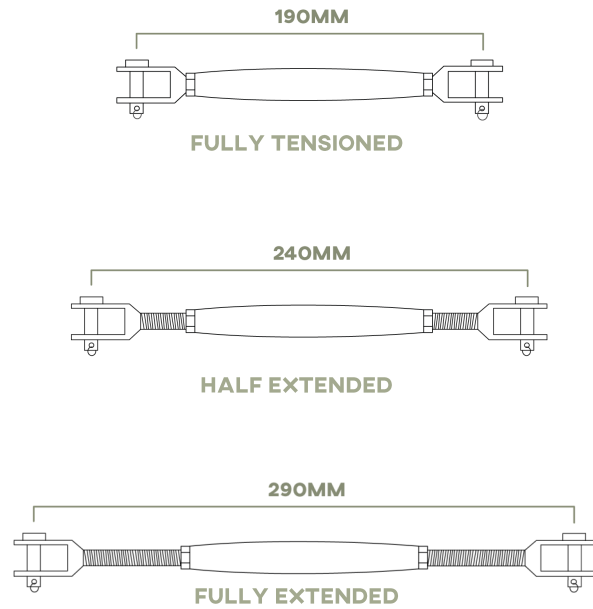
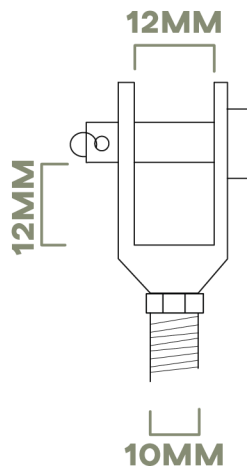

### M6 STANDARD

KSFX8PBT

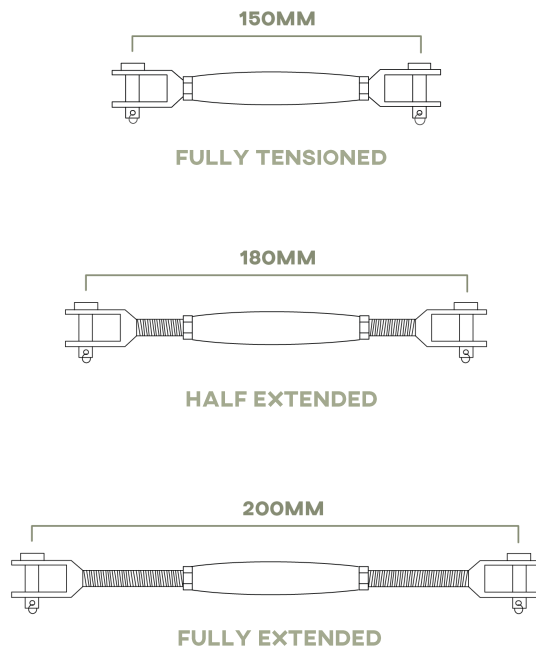
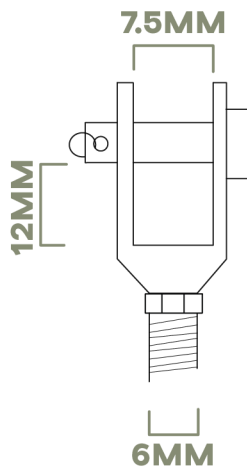



## SINGLE END TURNBUCKLES

### M8 STANDARD

KSFx8PBT

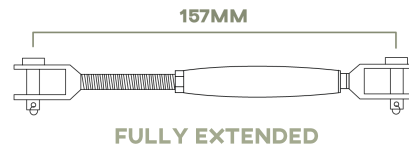
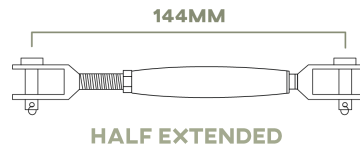
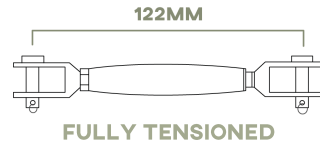
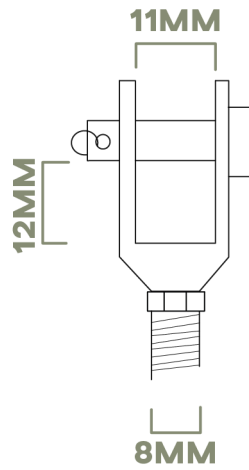

# SINGLE END FORK TURNBUCKLE



Each end are threaded in opposite directions so that when you rotate the body of the turnbuckle one way tension will be increased, rotate the other way and tension will be released. A versatile fixing which allows for adjustments in precise increments, there is a large variety of turnbuckles that have fork - fork attachments.

We only offer single end turnbuckles with an M8 screw (8mm), a wider range of dual end turnbuckles are available:

M8 Adjustable Turnbuckle

M8 Adjustable Turnbuckle (Short)

M10 Adjustable Turnbuckle

M6 Adjustable Turnbuckle

## HOW TO FIT

HANDHELD PLIERS



Some rules of thumb with turnbuckles are:

1. Make sure they are all evenly tensioned, if one is over tension and one under tensioned it will stretch the Shade.
2. Secure the Turnbuckle in place once tensioned correctly using the bolts, this will reduce slipping
3. Check the Turnbuckles once every couple of weeks, they will naturally slip slightly

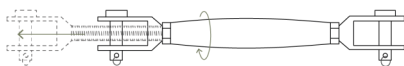

- 1 -

*Unwind Turnbuckle, apply lubrication to the screw such as lanolin - this will stop the thread from seizing up*

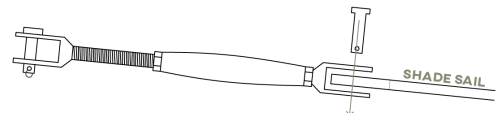

- 2 -

*Attach Shade Sail to fork connection at the fixed end of the Turnbuckle*

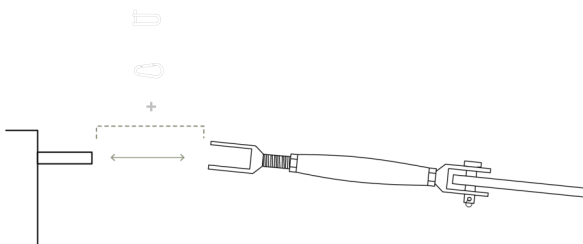

- 3 -

*Bridge any gap between Turnbuckle and anchor-age points with non-adjustable fixings*

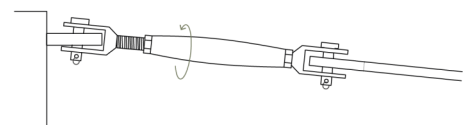

- 4 -

*Slowly tighten Turnbuckles, working around the Shade Sail. Continue until taught.*

*Secure in place by tightening bolts against central barrel*

# FORK - FORK TURNBUCKLE



Each end are threaded in opposite directions so that when you rotate the body of the turnbuckle one way tension will be increased, rotate the other way and tension will be released. A versatile fixing which allows for adjustments in precise increments, there is a large variety of turnbuckles that have fork - fork attachments.

We offer these Turnbuckles in numerous sizes and strengths:

M8 Adjustable Turnbuckle

M8 Adjustable Turnbuckle (Short)

M10 Adjustable Turnbuckle

M6 Adjustable Turnbuckle

## HOW TO FIT

HANDHELD PLIERS



Some rules of thumb with turnbuckles are:

1. Make sure they are all evenly tensioned, if one is over tension and one under tensioned it will stretch the Shade.
2. Secure the Turnbuckle in place once tensioned correctly using the bolts, this will reduce slipping
3. Check the Turnbuckles once every couple of weeks, they will naturally slip slightly

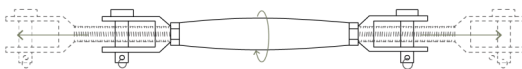

- 1 -

*Unwind Turnbuckle, apply lubrication to the screws such as lanolin - this will stop the thread from seizing up.*

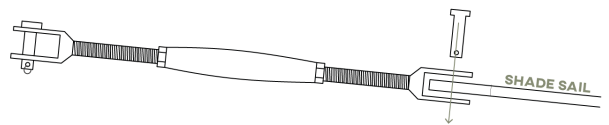

- 2 -

*Attach Shade Sail to fork connection at the fixed end of the Turnbuckle*

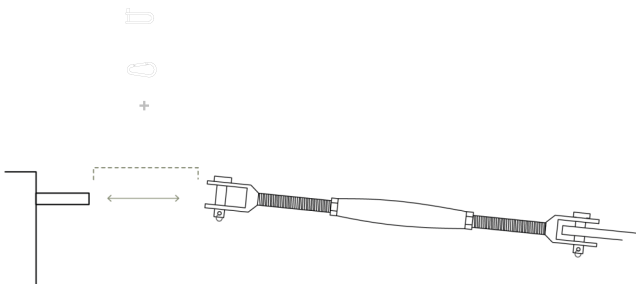

- 3 -

*Bridge any gap between Turnbuckle and anchorage points with non-adjustable fixings*

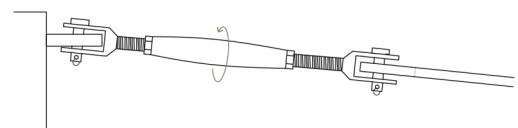

- 4 -

*Slowly tighten Turnbuckles, working around the Shade Sail. Continue until taut.*

*Secure in place by tightening bolts against central barrel*